

BGAV1A10

Low Noise Amplifier with Gain Control

Features

- Operating frequencies: 3.4 - 3.8 GHz
- Insertion power gain: 18.0 dB
- Gain dynamic range: 22 dB
- Low noise figure: 1.3 dB
- Low current consumption: 5.0 mA
- Multi-state control: Gain- and Bypass-Modes
- Small ATSLP leadless package

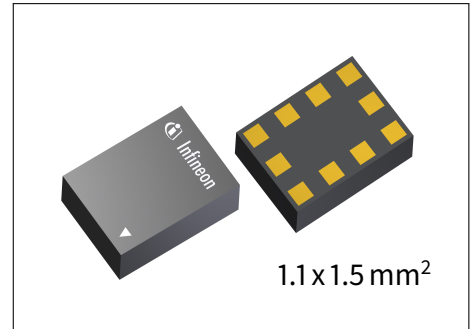

Application

The LTE data rate can be significantly improved by using the high gain LNA. The integrated gain control and bypass function increases the overall system dynamic range and leads to more flexibility in the front-end. In high gain mode the BGAV1A10 offers best Noise Figure to ensure high data rates even on the LTE cell edge. Closer to the basestation the bypass mode can be activated reducing current consumption. Thanks to the MIPI control interface, control lines are reduced to a minimum.

Product Validation

Qualified for industrial applications according to the relevant tests of JEDEC47/20/22.

Block diagram

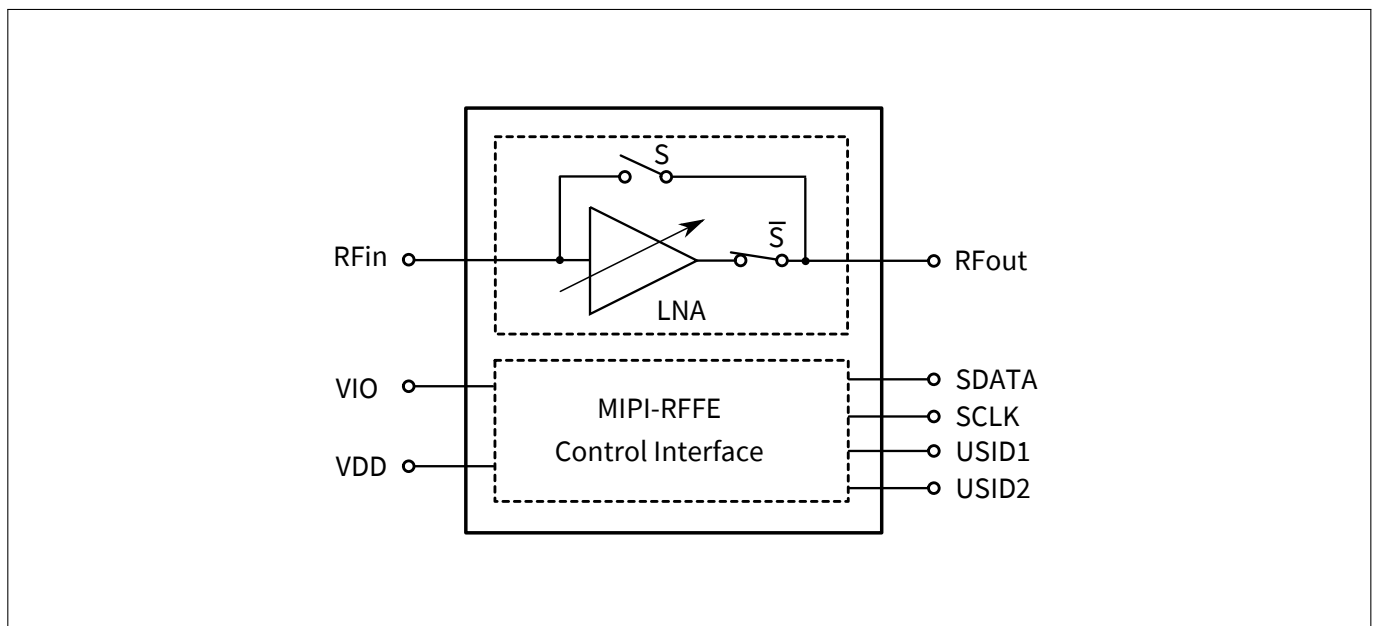

Table of Contents

Table of Contents	1
1 Maximum Ratings	2
2 DC Characteristics	3
3 RF Characteristics - Band 42	3
4 RF Characteristics - Band 43	5
5 MIPI RFFE Specification	8
6 Application Information	12
7 Package Information	14

Maximum Ratings

1 Maximum Ratings

Table 1: Maximum Ratings

Parameter	Symbol	Values			Unit	Note / Test Condition
		Min.	Typ.	Max.		
Supply Voltage VDD	V_{DD}	-0.3	–	2.5	V	¹
Voltage at RFin	V_{RFI}	-1	–	1	V	–
Voltage at RFout	V_{RFO}	-1	–	1	V	–
Current into pin VDD	I_{DD}	-30	–	–	mA	–
RF input power	P_{IN}	–	–	25	dBm	–
Total power dissipation	P_{tot}	–	–	90	mW	–
Junction temperature	T_J	–	–	150	°C	–
Ambient temperature range	T_A	-30	–	85	°C	–
Storage temperature range	T_{STG}	-55	–	150	°C	–
ESD capability, HBM	V_{ESD_HBM}	-1000	–	1000	V	²
RFFE Supply Voltage	V_{IO}	-0.5	–	2.7	V	–
RFFE Supply Voltage Levels	V_{SCLK} , V_{SDATA}	-0.7	–	$V_{IO} + 0.7$ (max. 2.7)	V	–

¹All voltages refer to GND-Nodes unless otherwise noted

²Human Body Model ANSI/ESDA/JEDEC JS-001-2014 ($R = 1.5\text{ k}\Omega$, $C = 100\text{ pF}$).

Attention: Stresses above the max. values listed here may cause permanent damage to the device. Maximum ratings are absolute ratings; exceeding only one of these values may cause irreversible damage to the integrated circuit. Exposure to conditions at or below absolute maximum rating but above the specified maximum operation conditions may affect device reliability and life time. Functionality of the device might not be given under these conditions.

BGAV1A10

Low Noise Amplifier with Gain Control

RF Characteristics - Band 42

2 DC Characteristics

Table 3: DC Characteristics at $T_A = 25^\circ\text{C}$

Parameter ¹	Symbol	Values			Unit	Note / Test Condition
		Min.	Typ.	Max.		
Supply Voltage	V_{DD}	1.7	1.8	1.9	V	–
Supply Current	I_{DD}	3.0	5.0	7.0	mA	G0-G3
		–	0.07	0.15	mA	G4
RFFE supply voltage	V_{IO}	1.65	1.8	1.95	V	–
RFFE input high voltage ²	V_{IH}	$0.7 * V_{IO}$	–	V_{IO}	V	–
RFFE input low voltage ²	V_{IL}	0	–	$0.3 * V_{IO}$	V	–
RFFE output high voltage ³	V_{OH}	$0.8 * V_{IO}$	–	V_{IO}	V	–
RFFE output low voltage ³	V_{OL}	0	–	$0.2 * V_{IO}$	V	–
RFFE control input capacitance	C_{Ctrl}	–	–	2	pF	–
RFFE supply current	I_{VIO}	–	3	–	μA	Idle State

¹Based on the application described in Chapter 6

²SCLK and SDATA

³SDATA

3 RF Characteristics - Band 42

Table 4: RF Characteristics in ON Mode at $T_A = 25^\circ\text{C}$, $V_{DD} = 1.8\text{ V}$, $I_{VDD} = 5.0\text{ mA}$, $f = 3.4\text{--}3.6\text{ GHz}$

Parameter	Symbol	Values			Unit	Note / Test Condition
		Min.	Typ.	Max.		
Insertion power gain $f = 3500\text{ MHz}$	$1/ S_{21} ^2$	16.0	18.0	20.0	dB	G0
		13.3	15.3	17.3	dB	G1
		6.9	8.9	10.9	dB	G2
		-2.7	-0.7	1.3	dB	G3
		-4.7	-2.7	-0.7	dB	G3 in Bias0 mode
		-5.4	-3.9	-2.4	dB	G4
Noise figure $f = 3500\text{ MHz}$	NF	–	1.3	1.8	dB	G0
		–	1.4	1.9	dB	G1
		–	1.5	2.0	dB	G2
		–	10.1	11.1	dB	G3
		–	3.9	5.4	dB	G4

Continued on next page

BGAV1A10

Low Noise Amplifier with Gain Control



RF Characteristics - Band 42

Table 4: RF Characteristics – Continued from previous page

Parameter	Symbol	Values			Unit	Note / Test Condition
		Min.	Typ.	Max.		
Input Return Loss $f = 3500$ MHz	RL_{in}	9	13	–	dB	G0
		9	13	–	dB	G1
		9	13	–	dB	G2
		6	9	–	dB	G3
		3	6	–	dB	G4
Output Return Loss $f = 3500$ MHz	RL_{out}	10	20	–	dB	G0
		10	20	–	dB	G1
		10	25	–	dB	G2
		10	18	–	dB	G3
		4	8	–	dB	G4
Reverse Isolation $f = 3500$ MHz	$1/ S_{12} ^2$	26	31	–	dB	G0
		29	34	–	dB	G1
		21	26	–	dB	G2
		27	32	–	dB	G3
		2.4	3.9	–	dB	G4
Inband input 1dB-compression point $f = 3500$ MHz	IP_{1dB}	-17	-13	–	dBm	G0
		-17	-13	–	dBm	G1
		-10	-6	–	dBm	G2
		-1	+3	–	dBm	G3
Inband input 3 rd -order intercept point ¹	$IIP3$	-8	-3	–	dBm	G0
		-8	-3	–	dBm	G1
		-4	+1	–	dBm	G2
		+4	+9	–	dBm	G3
		27	+32	–	dBm	G4
Phase discontinuity between all Gain Mode combinations $f = 3500$ MHz		-6	–	6	°	Part to part variation after compensation in Base Band with constant value
Stability	k	> 1	–	–		$f = 20$ MHz - 10 GHz
MIPI to RF time	t_{INT}	–	1.5	2	µs	50 % last SCLK falling edge to 90 % ON, see Fig. 2
Power Up Settling Time	t_{BC}	–	10	25	µs	After power down mode

¹Input power = –30 dBm for each tone for modes G0-G3 / –15 dBm for mode G4, $f_1 = 3500$ MHz, $f_2 = f_1 + 1$ MHz

4 RF Characteristics - Band 43

Table 5: RF Characteristics in ON Mode at $T_A = 25\text{ }^\circ\text{C}$, $V_{DD} = 1.8\text{ V}$, $I_{VDD} = 5.0\text{ mA}$, $f = 3.6\text{--}3.8\text{ GHz}$

Parameter	Symbol	Values			Unit	Note / Test Condition
		Min.	Typ.	Max.		
Insertion power gain $f = 3700\text{ MHz}$	$1/ S_{21} ^2$	15.6	17.6	19.6	dB	G0
		12.8	14.8	16.8	dB	G1
		6.4	8.4	10.4	dB	G2
		-2.9	-0.9	1.1	dB	G3
		-4.9	-2.9	-0.9	dB	G3 in Bias0 mode
		-5.4	-3.9	-2.4	dB	G4
Noise figure $f = 3700\text{ MHz}$	NF	-	1.4	1.9	dB	G0
		-	1.5	2.0	dB	G1
		-	1.6	2.1	dB	G2
		-	10.2	11.2	dB	G3
		-	3.9	5.4	dB	G4
Input Return Loss $f = 3700\text{ MHz}$	RL_{in}	6	9	-	dB	G0
		6	9	-	dB	G1
		7	10	-	dB	G2
		6	9	-	dB	G3
		4	7	-	dB	G4
Output Return Loss $f = 3700\text{ MHz}$	RL_{out}	10	14	-	dB	G0
		10	18	-	dB	G1
		10	20	-	dB	G2
		10	20	-	dB	G3
		8	11	-	dB	G4
Reverse Isolation $f = 3700\text{ MHz}$	$1/ S_{12} ^2$	27	32	-	dB	G0
		29	34	-	dB	G1
		22	27	-	dB	G2
		28	33	-	dB	G3
		2.4	3.9	-	dB	G4

Continued on next page

BGAV1A10

Low Noise Amplifier with Gain Control



RF Characteristics - Band 43

Table 5: RF Characteristics – Continued from previous page

Parameter	Symbol	Values			Unit	Note / Test Condition
		Min.	Typ.	Max.		
Inband input 1dB-compression point $f = 3700$ MHz	IP_{1dB}	-18	-14	-	dBm	G0
		-18	-14	-	dBm	G1
		-9	-5	-	dBm	G2
		-1	+3	-	dBm	G3
Inband input 3 rd -order intercept point ¹	$IIP3$	-10	-5	-	dBm	G0
		-10	-5	-	dBm	G1
		-5	0	-	dBm	G2
		+2	+7	-	dBm	G3
		25	+30	-	dBm	G4
Phase discontinuity between all Gain Mode combinations $f = 3700$ MHz		-6	-	6	°	Part to part variation after compensation in Base Band with constant value
Stability	k	> 1	-	-		$f = 20$ MHz - 10 GHz
MIPI to RF time	t_{INT}	-	1.5	2	μs	50 % last SCLK falling edge to 90 % ON, see Fig. 2
Power Up Settling Time	t_{BC}	-	10	25	μs	After power down mode

¹Input power = -30 dBm for each tone for modes G0-G3 / -15 dBm for mode G4, $f_1 = 3700$ MHz, $f_2 = f_1 + 1$ MHz

BGAV1A10

Low Noise Amplifier with Gain Control

RF Characteristics - Band 43

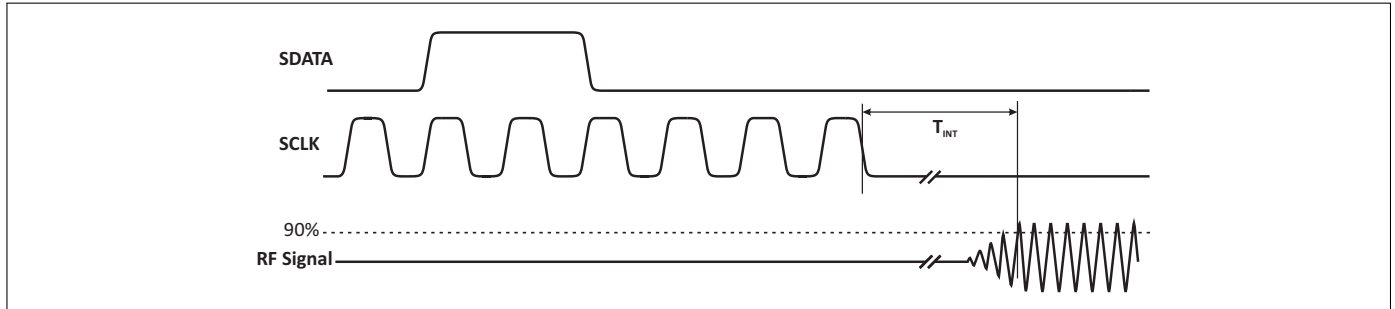

Figure 1: MIPI to RF Time

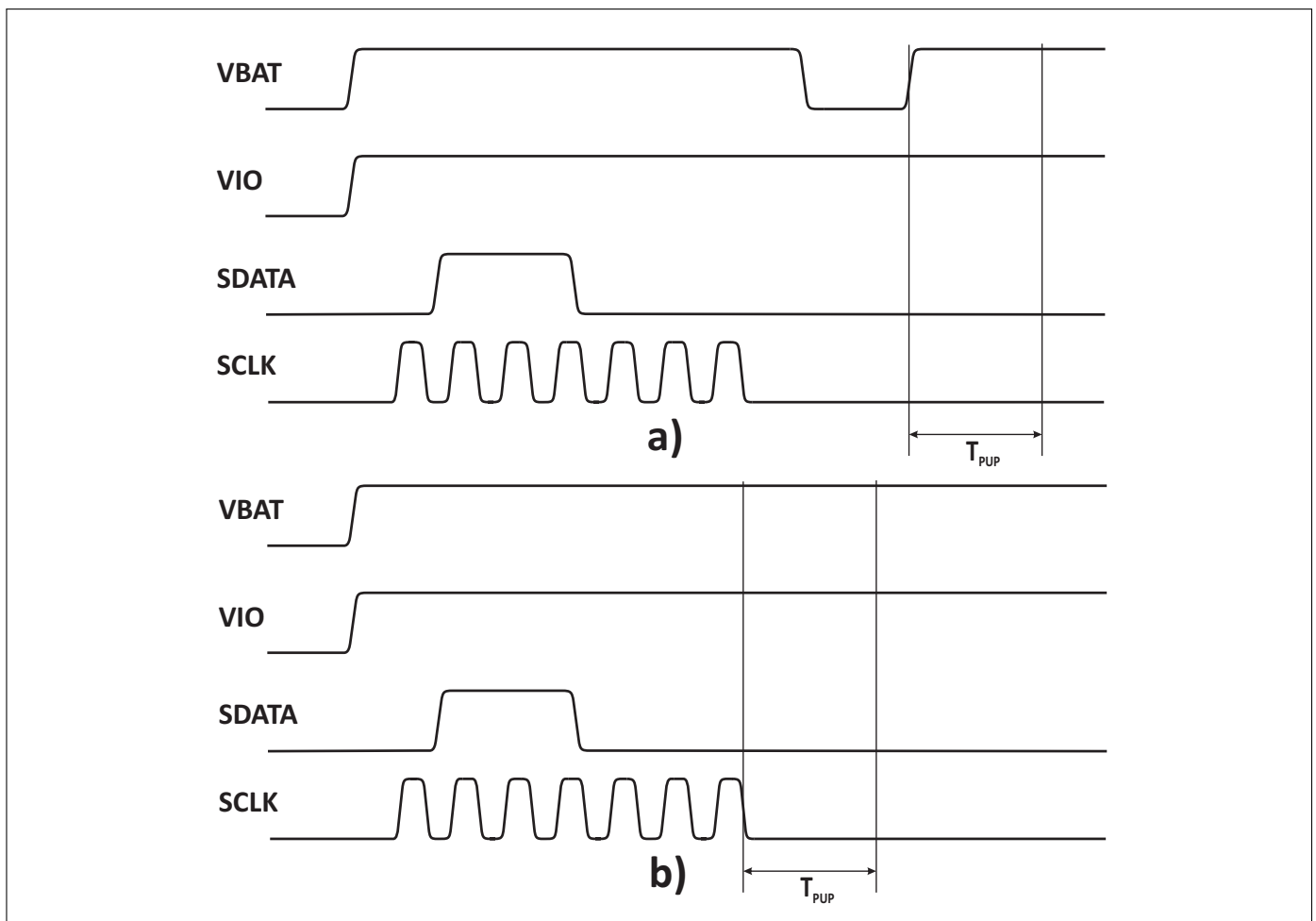

Figure 2: Power-Up Settling Time Definition: **a)** when the device is already in Active Mode. **b)** when changing from Low Power Mode to Active Mode.

After Power-Up of VIO the device is set to Low Power Mode. An additional MIPI instruction is necessary to set the device to Active Mode. This case is covered by **b)**.

BGAV1A10

Low Noise Amplifier with Gain Control

MIPI RFFE Specification

5 MIPI RFFE Specification

All sequences are implemented according to the 'MIPI Alliance Specification for RF Front-End Control Interface' document version 2.0 - 25. September 2014.

Table 6: MIPI Features

Feature	Supported	Comment
MIPI RFFE 2.0 standard	Yes	
Register 0 write command sequence	Yes	
Register read and write command sequence	Yes	
Extended register read and write command sequence	Yes	
Support for standard frequency range operations for SCLK	Yes	Up to 26 MHz for read and write
Support for extended frequency range operations for SCLK	Yes	Up to 52 MHz for write
Half speed read	Yes	
Full speed read	Yes	
Full speed write	Yes	
Programmable Group SID	Yes	
Programmable USID	Yes	Support for three registers write and extended write sequences
Trigger functionality	Yes	
Broadcast / GSID write to PM TRIG register	Yes	
Reset	Yes	Via VIO, PM TRIG or software register
Status / error sum register	Yes	
Extended product ID register	Yes	
Revision ID register	Yes	
Group SID register	Yes	
USID_Sel pin	Yes	External pin for changing USID: USID 12=00 → 1000, USID 12=10 → 1001, USID 12=01 → 1010, USID 12=11 → 1011
USID selection via SDATA / SCLK swap feature	No	

Table 7: Startup Behavior

Feature	State	Comment
Power status	Low power	Lower power mode after start-up
Trigger function	Enabled	Enabled after start-up. Programmable via behavior control register

BGAV1A10

Low Noise Amplifier with Gain Control



MIPI RFFE Specification

Table 8: Register Mapping, Table I

Register Address	Register Name	Data Bits	Function	Description	Default	Broadcast_ID Support	Trigger Support	R/W	
0x00	REGISTER_0	7:0	MODE_CTRL	LNA control	00000000	No	Yes	R/W	
0x1C	PM_TRIG	7	PWR_MODE(1), Operation Mode	0: Normal operation (ACTIVE)	1	Yes	No	R/W	
				1: Low Power Mode (LOW POWER)					
		6	PWR_MODE(0), State Bit Vector	0: No action (ACTIVE)	0				
				1: Powered Reset (STARTUP to ACTIVE to LOW POWER)					
		5	TRIGGER_MASK_2	0: Data masked (held in shadow REG)	0				No
				1: Data not masked (ready for transfer to active REG)					
		4	TRIGGER_MASK_1	0: Data masked (held in shadow REG)	0				
				1: Data not masked (ready for transfer to active REG)					
		3	TRIGGER_MASK_0	0: Data masked (held in shadow REG)	0				
1: Data not masked (ready for transfer to active REG)									
2	TRIGGER_2	0: No action (data held in shadow REG)	0	Yes					
		1: Data transferred to active REG							
1	TRIGGER_1	0: No action (data held in shadow REG)	0						
		1: Data transferred to active REG							
0	TRIGGER_0	0: No action (data held in shadow REG)	0						
		1: Data transferred to active REG							
0x1D	PRODUCT_ID	7:0	PRODUCT_ID		This is a read-only register. However, during the programming of the USID a write command sequence is performed on this register, even though the write does not change its value.	00001101	No	No	R
0x1E	MAN_ID	7:0	MANUFACTURER_ID [7:0]		This is a read-only register. However, during the programming of the USID, a write command sequence is performed on this register, even though the write does not change its value.	00011010	No	No	R
0x1F	MAN_USID	7:6	RESERVED		Reserved for future use	00	No	No	R
		5:4	MANUFACTURER_ID [9:8]	These bits are read-only. However, during the programming of the USID, a write command sequence is performed on this register even though the write does not change its value.	01				
		3:0	USID[3:0]	Programmable USID. Performing a write to this register using the described programming sequences will program the USID in devices supporting this feature. These bits store the USID of the device.	See Tab. 6	No	No	R/W	

BGAV1A10

Low Noise Amplifier with Gain Control



MIPI RFFE Specification

Table 9: Register Mapping, Table II

Register Address	Register Name	Data Bits	Function	Description	Default	Broadcast_ID Support	Trigger Support	R/W
0x20	EXT_PRODUCT_ID	7:0	EXT_PRODUCT_ID		00000000	No	No	R
0x21	REV_ID	7:4	MAIN_REVISION		0001	No	No	R/W
		3:0	SUB_REVISION		0000			
0x22	GSID	7:4	GSID0[3:0]	Primary Group Slave ID.	0000	No	No	R/W
		3:0	RESERVED	Reserved for secondary Group Slave ID.	0000			
0x23	UDR_RST	7	UDR_RST	Reset all configurable non-RFFE Reserved registers to default values. 0: Normal operation 1: Software reset	0	No	No	R/W
		6:0	RESERVED	Reserved for future use	0000000			
0x24	ERR_SUM	7	RESERVED	Reserved for future use	0	No	No	R
		6	COMMAND_FRAME_PARITY_ERR	Command Sequence received with parity error – discard command.	0			
		5	COMMAND_LENGTH_ERR	Command length error.	0			
		4	ADDRESS_FRAME_PARITY_ERR	Address frame with parity error.	0			
		3	DATA_FRAME_PARITY_ERR	Data frame with parity error.	0			
		2	READ_UNUSED_REG	Read command to an invalid address.	0			
		1	WRITE_UNUSED_REG	Write command to an invalid address.	0			
0x78	DFT	7:0	DESIGN_FOR_TEST	Do not use.	–	–	–	–

BGAV1A10

Low Noise Amplifier with Gain Control



MIPI RFFE Specification

Table 10: Gain Modes of Operation (Truth Table, Register_0)

State	Mode	REGISTER_0 Bits						
		D6	D5	D4	D3	D2	D1	D0
1	Gain G0	1	0	0	1	x	x	x
2	Gain G1	1	0	1	1	x	x	x
3	Gain G2	1	1	0	1	x	x	x
4	Gain G3	1	1	1	0	x	x	x
5	Gain G4 (Bypass)	0	1	1	1	x	x	x

Table 11: Bias settings (Truth Table, Register_0)

State	Mode	REGISTER_0 Bits						
		D6	D5	D4	D3	D2	D1	D0
9	Bias0 (3.0 mA)	1	x	x	x	0	0	0
10	Bias1 (3.5 mA)	1	x	x	x	0	0	1
11	Bias2 (4.0 mA)	1	x	x	x	0	1	0
12	Bias3 (4.5 mA)	1	x	x	x	0	1	1
13	Bias4 (5.0 mA) ¹	1	x	x	x	1	0	0
14	Bias5 (5.5 mA)	1	x	x	x	1	0	1
15	Bias6 (6.0 mA)	1	x	x	x	1	1	0
16	Bias7 (6.5 mA)	1	x	x	x	1	1	1

¹Target bias mode for Gain modes G0-G3

BGAV1A10

Low Noise Amplifier with Gain Control

Application Information

6 Application Information

Pin Configuration and Function

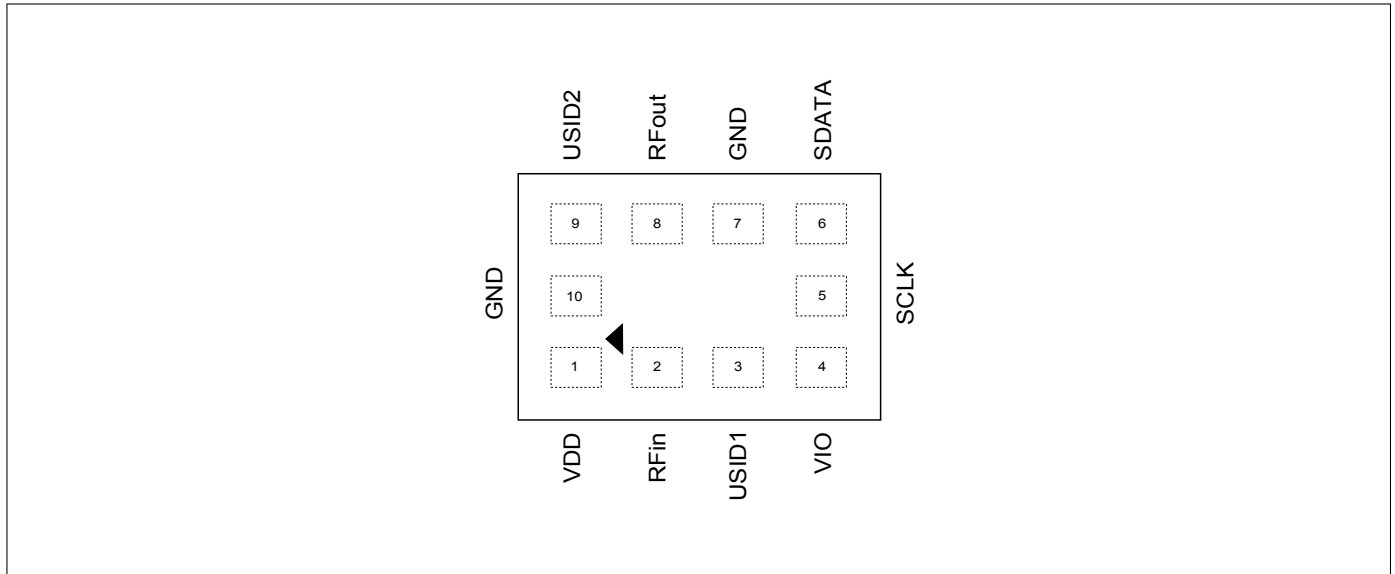

Figure 3: BGAV1A10 Pin Configuration (top view)

Table 12: Pin Definition and Function

Pin No.	Name	Function
1	VDD	Power supply
2	RFIn	RF input port
3	USID1	USID select pin 1
4	VIO	MIPI RFFE supply
5	SCLK	MIPI RFFE clock
6	SDATA	MIPI RFFE data
7	GND	Ground
8	RFout	RF output port
9	USID2	USID select pin 2
10	GND	Ground

¹ Leave unconnected if not used (do NOT connect to GND)

BGAV1A10

Low Noise Amplifier with Gain Control

Application Information

Application Board Configuration

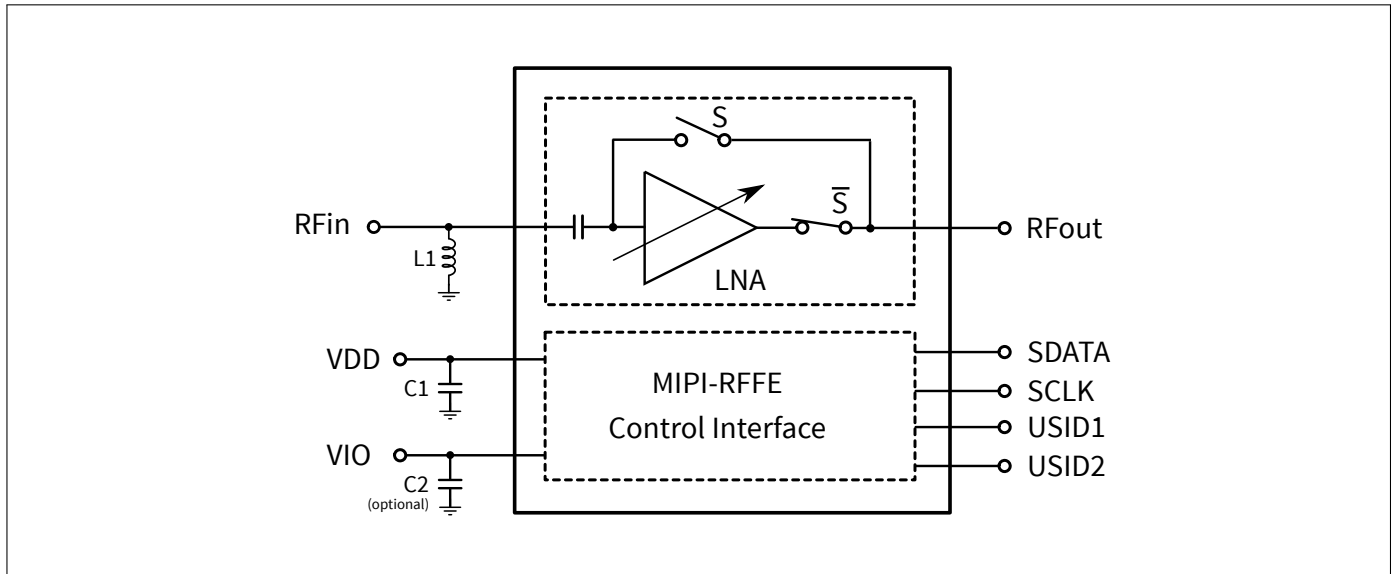

Figure 4: BGAV1A10 Application Schematic

Table 13: Bill of Materials Table

Name	Value	Package	Manufacturer	Function
C1	10 nF	0201	Various	RF bypass ¹
C2 (optional)	10 nF	0201	Various	RF bypass ¹
L1	1.5nH	0201	muRata LQP type	Input matching ²
N1	BGAV1A10	ATSLP-10-1	Infineon	Variable gainstep LNA

¹RF bypass recommended to mitigate power supply noise.

²The matching elements must be optimized with reference to the frequency band of interest.

BGAV1A10

Low Noise Amplifier with Gain Control

Package Information

7 Package Information

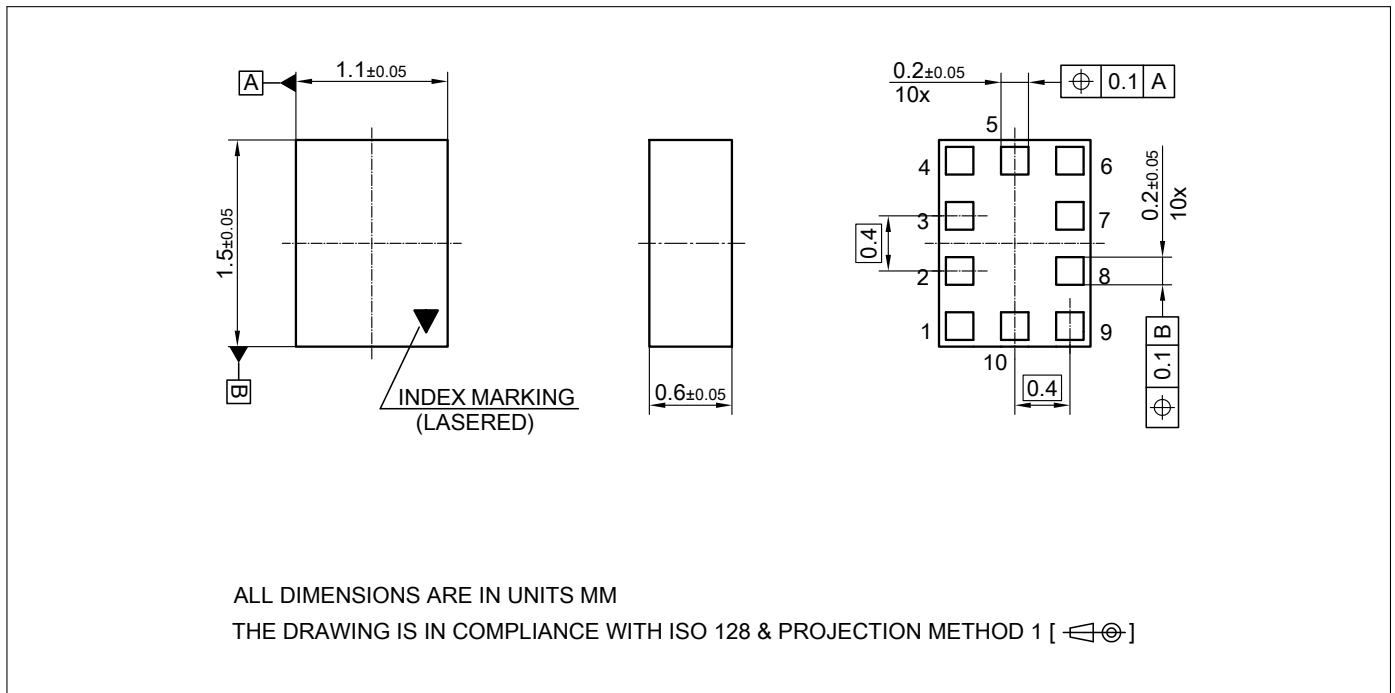

Figure 5: ATSLP-10-1 Package Outline (top, side and bottom views)

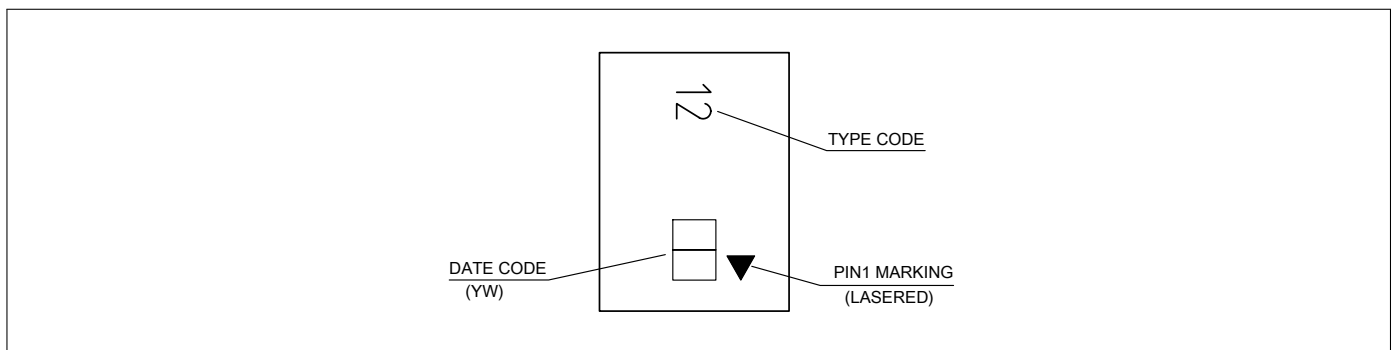

Figure 6: Marking Specification (top view)

Product Name	Marking	Package
BGAV1A10	V1	ATSLP-10-1

Table 14: Year date code marking - digit "Y"

Year	"Y"	Year	"Y"	Year	"Y"
2000	0	2010	0	2020	0
2001	1	2011	1	2021	1
2002	2	2012	2	2022	2
2003	3	2013	3	2023	3
2004	4	2014	4	2024	4
2005	5	2015	5	2025	5
2006	6	2016	6	2026	6
2007	7	2017	7	2027	7
2008	8	2018	8	2028	8
2009	9	2019	9	2029	9

Table 15: Week date code marking - digit "W"

Week	"W"	Week	"W"	Week	"W"	Week	"W"	Week	"W"
1	A	12	N	23	4	34	h	45	v
2	B	13	P	24	5	35	j	46	x
3	C	14	Q	25	6	36	k	47	y
4	D	15	R	26	7	37	l	48	z
5	E	16	S	27	a	38	n	49	8
6	F	17	T	28	b	39	p	50	9
7	G	18	U	29	c	40	q	51	2
8	H	19	V	30	d	41	r	52	3
9	J	20	W	31	e	42	s	53	M
10	K	21	Y	32	f	43	t		
11	L	22	Z	33	g	44	u		

BGAV1A10

Low Noise Amplifier with Gain Control

Package Information

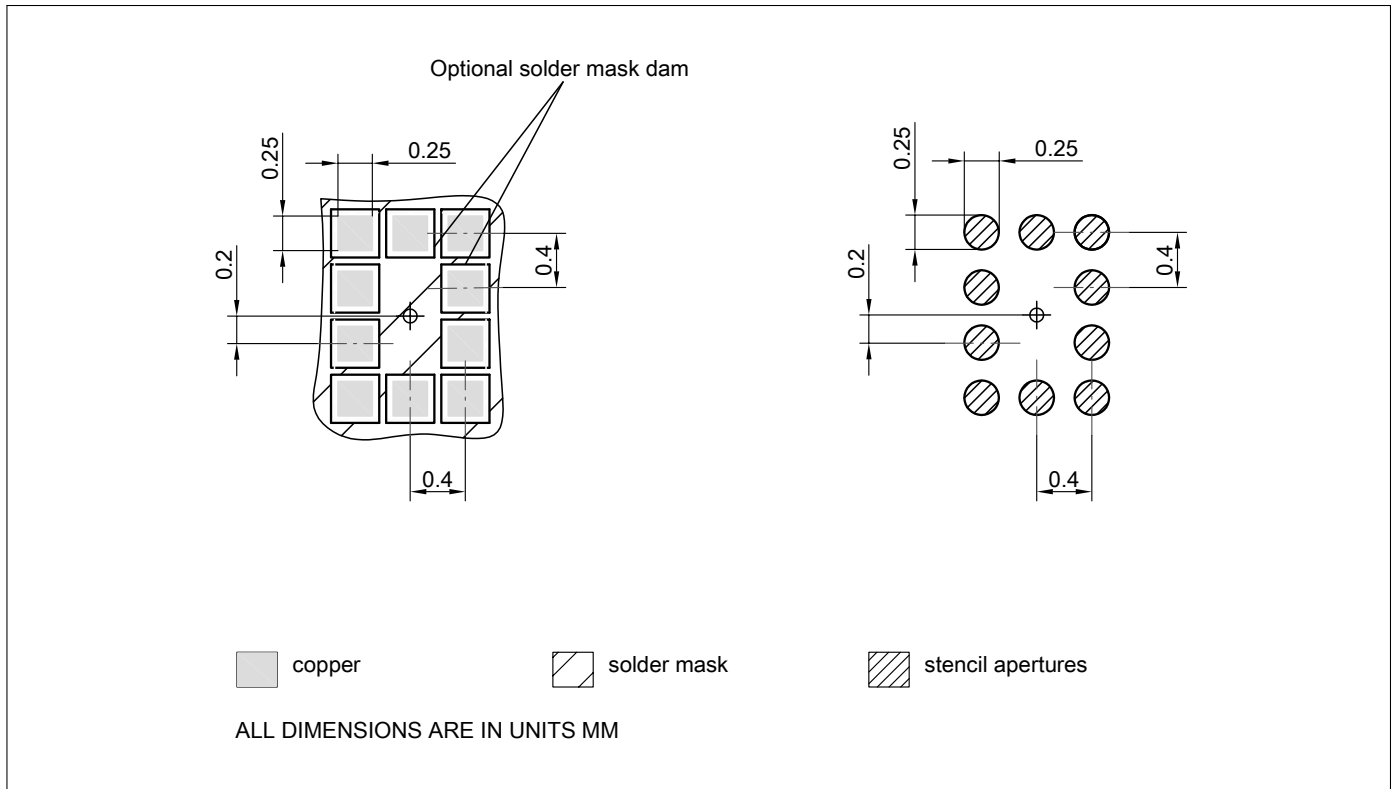
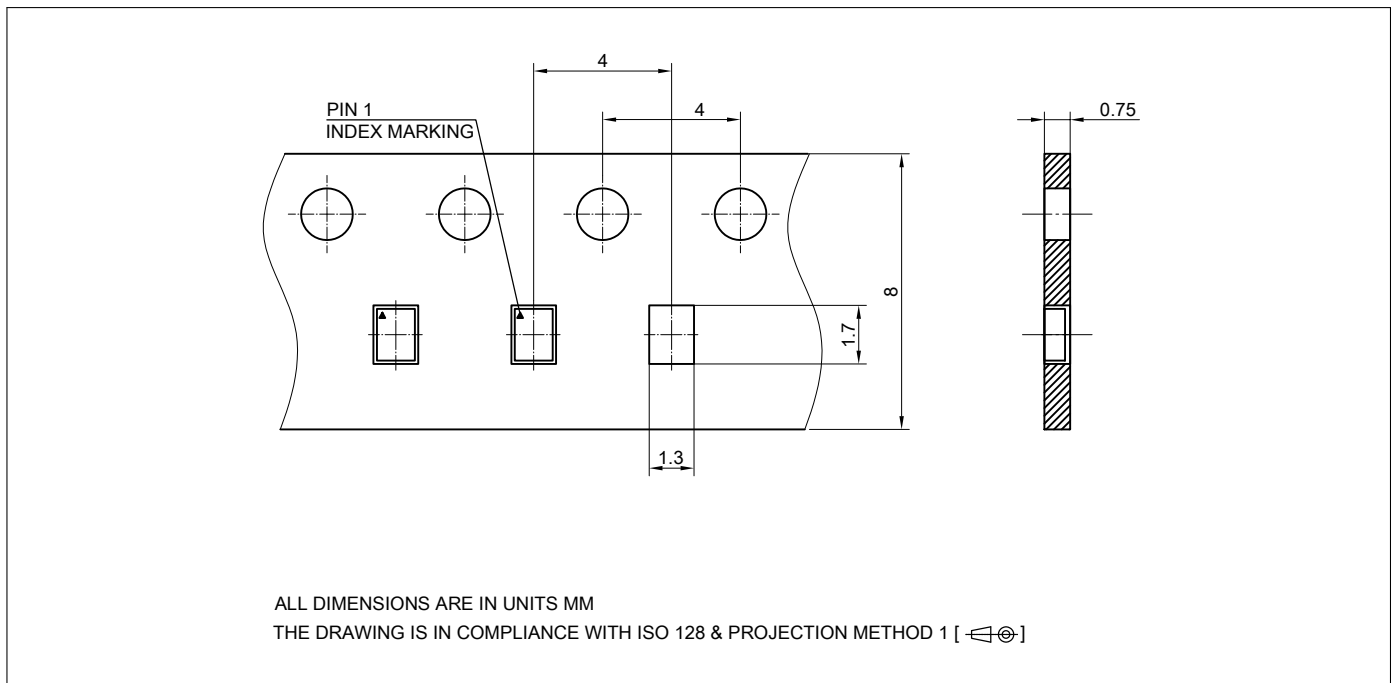

Figure 7: Footprint Recommendation



Revision History

Page or Item	Subjects (major changes since previous revision)
Revision 3.0, 2018-04-23	
all	"Preliminary" removed
2	Maximum current into pin VDD updated
2	Maximum RF input power updated
2	Maximum total power dissipation updated
14	Package outline drawing updated
14	Marking specification drawing updated
15	Date code marking tables added
16	Footprint recommendation drawing added
16	Carrier tape drawing added
17	Trademarks updated

Other Trademarks

All referenced product or service names and trademarks are the property of their respective owners.

Edition 2018-04-23

Published by
Infineon Technologies AG
81726 Munich, Germany

© 2018 Infineon Technologies AG.
All Rights Reserved.

Do you have a question about any
aspect of this document?

Email: erratum@infineon.com

Document reference

Doc_Number

IMPORTANT NOTICE

The information given in this document shall in no event be regarded as a guarantee of conditions or characteristics ("Beschaffheitsgarantie"). With respect to any examples, hints or any typical values stated herein and/or any information regarding the application of the product, Infineon Technologies hereby disclaims any and all warranties and liabilities of any kind, including without limitation warranties of non-infringement of intellectual property rights of any third party. In addition, any information given in this document is subject to customer's compliance with its obligations stated in this document and any applicable legal requirements, norms and standards concerning customer's products and any use of the product of Infineon Technologies in customer's applications. The data contained in this document is exclusively intended for technically trained staff. It is the responsibility of customer's technical departments to evaluate the suitability of the product for the intended application and the completeness of the product information given in this document with respect to such application.

For further information on technology, delivery terms and conditions and prices, please contact the nearest Infineon Technologies Office (www.infineon.com).

WARNINGS

Due to technical requirements products may contain dangerous substances. For information on the types in question please contact your nearest Infineon Technologies office.

Except as otherwise explicitly approved by Infineon Technologies in a written document signed by authorized representatives of Infineon Technologies, Infineon Technologies products may not be used in any applications where a failure of the product or any consequences of the use thereof can reasonably be expected to result in personal injury.